

Price: \$5.00

MODEL SP-7 PREAMPLIFIER

OWNER'S MANUAL

10/1/86

audio research corporation

6801 SHINGLE CREEK PARKWAY
MINNEAPOLIS, MINNESOTA 55430

TABLE OF CONTENTS

<u>SECTION</u>	<u>PAGE</u>
INTRODUCTION	1
USE CAUTIONS	1
PACKAGING	2
DESCRIPTION	2-3
FRONT PANEL CONTROLS	4-5
REAR PANEL CONNECTIONS	6-7
OPERATION	8
SERVICING	8-9
WARRANTY TERMS AND CONDITIONS	10-11
WARRANTY OUTSIDE THE USA	11
SPECIFICATIONS	12
ADDENDUM: SCHEMATIC	

INTRODUCTION

Congratulations on your purchase. The Audio Research SP-7 stereo preamplifier was conceived and designed to provide solid state-of-the-art high definition with "musical" reproduction of sound at an affordable price for audio perfectionists. "Analog Module"® solid-state circuitry provides extremely wide musical bandwidth under actual dynamic listening conditions. Conservative design and extensive use of high quality industrial grade components insure many years of trouble-free performance and musical satisfaction.

USE CAUTIONS

1. Please be certain to read this manual over to familiarize yourself with your new preamplifier before placing it in service.
2. The power cord on your SP-7 is equipped with a standard three-prong grounding plug which, if used normally, will provide a safe earth ground connection for the SP-7 chassis and all equipment plugged into its AC receptacles. While this procedure provides the maximum possible safety in use it will, in some cases, cause your audio system to have a small residual hum.

It is usually best to keep the SP-7 earth grounded and "float" the grounds of power amplifiers plugged into the SP-7 to eliminate any ground loop hum. The audio interconnect cables then keep the power amplifiers at safe earth ground potential. For further information on grounding, see INSTALLATION on Page 7 of this manual. If there is any question as to the safety of grounding procedures, be certain to seek competent help with the installation.

WARNING

1. To prevent fire or shock hazard, do not expose this equipment to rain or moisture.
2. This unit contains voltages which can be dangerous. Do not operate this unit with its covers removed. Refer servicing to qualified personnel.

CAUTION

For continued protection against fire hazard, replace the fuse only with same type and rating of fuse as specified at the fuse holder.

PACKAGING

Save all packaging. Your Audio Research® preamplifier is a precision electronic instrument and should be properly cartoned any time shipment is made. You may not have occasion to return it to the factory for service, but if that should prove necessary, or other occasion to ship it occurs, the original packaging may save your investment from unnecessary damage or delay.

DESCRIPTION

The heart of the SP-7 preamplifier design is the Analog Module® amplification concept. The four AM-8 Analog Modules® are the result of a search for a solid-state approach that provides superior musically-accurate performance along with immunity from the sonic degradation of power supply and coupling functions. These modules are highly linear with precise symmetry and balance, along with extremely wide bandwidth. The exceptional dynamic range results from a very low noise floor, careful choice of operating currents and a controlled overload characteristic. The accuracy of musical definition is enhanced by elimination of all audio coupling capacitors and all electrolytic bypass capacitors.

Four high-speed "zero-impedance" electronic regulators are used for total isolation between phono and hi-level amplification sections. These regulators are controlled by precision tracking reference voltage sources with controlled turn-on characteristics. Servo sensors for DC balancing are energized immediately at turn-on, so that safe and silent performance is insured even during final stabilization of the tracking reference voltages. The SP-7 is fully operational within 10 seconds and fully balanced in about 40 seconds. No warm-up muting circuitry is required.

Although the SP-7 has no coupling capacitors, it is technically not "DC-coupled" since it will not pass continuous DC signals. Servo correction circuits are used to maintain DC balance at all times. Sub-sonic response is extended below 0.1Hz to preserve integrity of attack transients such as drum impacts without ringing or overshoot from sharp-cutoff circuitry. The use of

controlled time constants in the servo correction circuits and minimum capacitive energy storage in the SP-7 essentially eliminate the possibility of accidental sub-sonic damage to power amplifiers or speakers. Still, with any truly wide band preamp, care must be taken to use only stable, high quality turntables and pickups and adequate fuse protection for loudspeakers. You may find a tendency to "play louder" to enjoy the full realism attainable and fail to consider speaker limitations.

The SP-7 is designed to provide functional simplicity to maximize sonic integrity. For this reason no tone controls or filters are provided, and a minimum of switching is provided. Circuit gain is carefully chosen to provide unexcelled "head-room" and phono overload characteristics for a solid-state preamp. This results in a very high degree of compatibility with input and output components in your system. The output circuits in the SP-7 will tolerate an exceptionally wide range of cables and load impedances without any loss of high or low frequency response, or degradation of distortion or peak output capabilities.

The rugged, classic construction is designed to withstand a lifetime of heavy useage. Scuff-resistant finishes are used on heavy guage aluminum and steel chassis parts, crowned with the durable 3/16" anodized aluminum panel, solid aluminum knobs and heavy-duty handles. Internally the same attention is given to quality, with the double-plated, 2-sided, plated-through epoxy circuit board and sonically selected components and wiring. Low impedance grounding and full RFI suppression provide interference-free operation in RF-polluted metropolitan environments. Gain and balance controls utilize carefully selected contact materials and chemical treatment to provide both long life and sonic accuracy.

We suggest that inclusion of this preamp in any otherwise good music reproducing system will effect more audible improvement than any other single component change. For further discussion of performance and system requirements we encourage you to see your Audio Research Dealer.

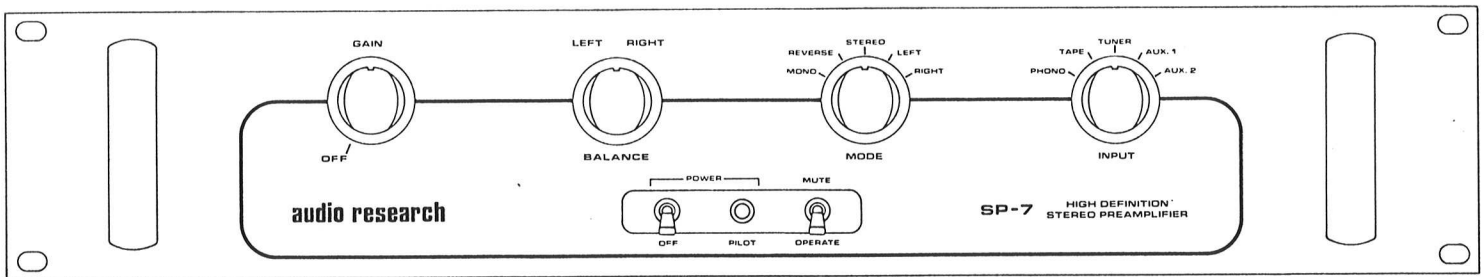

FRONT PANEL LAYOUT

FRONT PANEL CONTROLS (Refer to the "Front Panel Layout" diagram above)

Rotary Controls:

Volume: Controls stereo preamplifier "main output" level. Power amplifier or source gain controls (if available) should be set such that normal listening levels occur at approximately a 1 or 2 o'clock setting. This will provide ideal volume control "resolution."

Balance: Controls the relative volume of each channel. Equal channel volume occurs when the control is centered at the indicator mark. Clockwise rotation from center position decreases left channel output. Counterclockwise rotation decreases right channel output.

Rotary Switches:

Mode: Switch selects one of five "main output" modes:

"Mono" - Combines the left and right input channels internally to provide monaural output (common output for both left and right main outputs).

"Reverse" - Provides stereophonic operation except channels are reversed, ie: left input to right output, right input to left output.

"Stereo" - Provides normal stereophonic operation without channel reversal, ie: left input to left output, right input to right output.

"Left" - Left channel input sources are coupled to both the left and right "main outputs" simultaneously. The "balance" control functions as normal.

"Right" - Same as above except right channel input sources are coupled to both the left and right "main outputs" simultaneously.

Note: The "tape outputs" are unaffected by the position of the "mode" switch.

Input: Switch selects one of five rear panel inputs (program sources) as marked. All unused inputs are shorted to ground through 39K ohm isolation resistors.

Toggle Switches:

Power: Controls the power relay for the two switched AC power receptacles for power amplifiers or other equipment. The preamp itself is on continuously to ensure full operating temperature for all components for best sonic performance. Up to 24 hours of stabilization is desirable after the SP-7 is first plugged in to achieve full sonic results. Power consumption is about 7 watts, no more than 2 or 3 electronic clocks, when this switch is off. (Note: Early SP-7 models controlled all preamp and switched accessory power with this switch. See schematic diagram for details.)

Mute: Shorts the main outputs to allow silent changing of records or inputs while preserving volume settings, or for program interruption for discussion, etc. For best results always leave in "mute" position when the system is not being used.

Indicator:

LED: Green light emitting diode. Illuminates when power switch is "on." See discussion above.

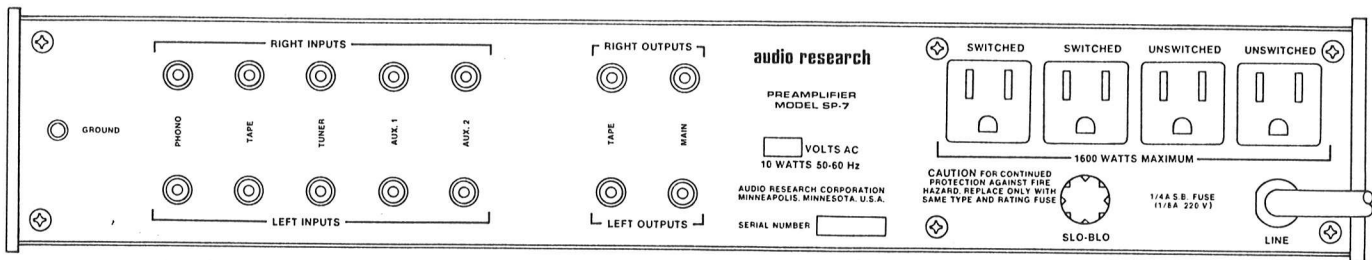

REAR PANEL LAYOUT

REAR PANEL CONNECTIONS (Refer to the "Rear Panel Layout" diagram above)

Audio Inputs:

Phono: Connect to magnetic phono pickup arm/cartridge. These inputs provide nominal 50K ohm and 30pF cartridge loading and RIAA playback compensation. Additional capacitance or resistance loading may be added internally according to the cartridge manufacturer's recommendations. Include turntable cable capacitance in calculations. Use an external step-up device such as the Audio Research MCP-2 for moving coil cartridges.

Connect the phono pickup system grounding wire to the "ground" terminal post. If hum is added by this connection in certain systems, no ground is required.

Tape, Tuner, Aux 1, Aux 2: High level inputs. Connect to output of tape recorder line outputs, tuners or any amplified source rated at 50mV or higher output level. Input impedance is 90K ohms and 50pF.

Audio Outputs:

Tape: Connect to tape recorder line inputs. Provides preamplified, RIAA equalized phono output for tape recording when "tape" is selected by the input selector. This is unaffected by gain, balance, mode or mute controls. Use tape monitor switching on your tape recorder for monitoring of tape playback during recording. For best results use short (6 ft. max) interconnect cables with 200pF maximum load capacitance. Minimum recommended resistive load is 10K ohms. Source impedance is 1200 ohms.

Main: Connect to power amplifier or electronic crossover inputs. The 250 ohm output impedance is compatible with virtually any loads or cables. See specifications for details.

Switched AC Receptacles:

Connect power cords from power amplifiers, crossovers, etc., that need controlling by the SP-7 front panel power switch. The heavy duty 30 amp relay handles high surge loads. Load capacity is 1600 watts maximum including the unswitched receptacles. These outlets are not fuse protected.

Note: Three-prong grounding receptacles are provided to accommodate power amplifiers with three-prong line plugs. To avoid system ground loop hum, it may be necessary in some systems to isolate these cords with three-to-two-prong adapters.

Unswitched AC Receptacles:

Connect power cords from turntables, tuners or headamps that have their own power switches, or which may need warmup stabilization prior to turning on the power amplifiers. These outlets are not fuse protected.

Fuse:

Provides protection for internal preamp electronics only. Replace only with 1/4A slow-blow fuse (1/8A for 220-240V).

INSTALLATION

Before connecting your SP-7 into your music system familiarize yourself with front and rear panel functions discussed above.

Connect all audio interconnect cables before applying power to the system. To fully experience the sonic capabilities of the SP-7 we recommend the use of the shortest and best sonically available interconnect cables. Make sure that all cables are fully inserted and that the ground fingers are making firm contact with the SP-7 jacks. Dress all audio cables, especially phono cartridge cables, away from all power cords for minimum hum and noise interference.

Make sure that adequate ventilation is provided for power amplifiers, to avoid "cooking" the SP-7 with heat from other units and thereby possibly shortening its life. Some power amplifiers may have sufficient magnetic fields to introduce hum into the SP-7, even though the SP-7 is well shielded. If this occurs, move the SP-7 several inches further away from the power amplifier. Audio Research manufactures an accessory (RMV-3) for providing proper ventilation and heat isolation from product to product when "rack mount" type systems are employed. See your Audio Research Dealer for discussion about this.

Connect the SP-7 power cord to an AC wall receptacle with minimum use of extension cords or other loads on the same circuit, primarily to insure minimum voltage loss for the power amplifiers that may be connected to the receptacles on the rear of the SP-7.

If system hum occurs due to ground loops in system interconnection, isolate the power amplifier AC power cords with three-to-two-prong adapters at the rear of the SP-7. In severe cases it may be necessary to insulate the SP-7 from its rack mounting with insulating washers.

OPERATION

Before operating, familiarize yourself with the front panel control functions discussed above. To properly and safely operate your music system proceed as follows:

1. Set "GAIN" control at minimum (counter-clockwise).
2. Set "MUTE" switch to "MUTE".
3. Turn power switch "ON". Green LED should illuminate.
4. Turn on desired program source.
5. Select "INPUT" switch to the program source desired.
6. Set "MODE" switch to "STEREO".
7. Set "BALANCE" control to 12 o'clock position.
8. Set "MUTE" switch to "OPERATE".
9. Turn "GAIN" control clockwise for desired listening volume.

SERVICING

In case of difficulty after connecting the SP-7 into your system a list of common system problems and possible causes is provided below to aid in troubleshooting:

<u>Symptom</u>	<u>Possible Cause</u>
Both Channels Dead	<ul style="list-style-type: none">-Power amplifier off-Controls improperly set-Improper interconnect wiring-Defective signal source-Blown power amplifier fuse-Blown SP-7 fuse
One Channel Dead	<ul style="list-style-type: none">-Balance control not centered-Defective audio cable-Improper interconnect wiring-Defective signal source
Hum or Noise	<ul style="list-style-type: none">-System ground loop-Turntable not grounded-Poor interconnect wiring-Defective audio cable-Excessive lead length-Defective signal source
High Distortion	<ul style="list-style-type: none">-Low AC line voltage-Loudspeaker-turntable mechanical feedback-Defective cartridge or source

CAUTION: The SP-7 contains voltages that can be dangerous. There are no user adjustments inside the unit. Do not operate with covers removed. Refer all servicing to qualified personnel.

In the event that service becomes necessary, contact your Audio Research Dealer or Customer Service at Audio Research for a return authorization. The original equipment packaging should be used any time shipment is made.

All shipments to the factory must be prepaid and insured for full value. All factory serviced equipment will be returned freight prepaid by Audio Research for warranty repair service. In the event that chargeable repairs are required, you will be contacted prior to the return of your equipment. See Warranty provisions.

3-YEAR LIMITED WARRANTY TERMS AND CONDITIONS

1. LIMITED WARRANTY. Audio Research warrants the product designated herein to be free of manufacturing defects in material and workmanship, subject to the conditions hereinafter set forth, for a period of three (3) years from the date of purchase by the original purchaser or no later than five (5) years from the date of shipment to the authorized Audio Research dealer, whichever comes first, excepting vacuum tubes which are warranted for 90 days only (See 6).
2. CONDITIONS. This Warranty is subject to the following conditions and limitations. The Warranty is void and inapplicable if the product has been used or handled other than in accordance with the instructions in the owner's manual, abused or misused, damaged by accident or neglect or in being transported, or the defect is due to the product being repaired or tampered with by anyone other than Audio Research or an authorized Audio Research repair center. The product must be packed and returned to Audio Research or an authorized Audio Research repair center by the customer at his or her sole expense. Audio Research will pay return freight of its choice. A RETURNED PRODUCT MUST BE ACCOMPANIED BY A WRITTEN DESCRIPTION OF THE DEFECT AND A PHOTOCOPY OF THE ORIGINAL PURCHASE RECEIPT. This receipt must clearly list model and serial number, the date of purchase, the name and address of the purchaser and authorized dealer and the price paid by the purchaser. Audio Research reserves the right to modify the design of any product without obligation to purchasers of previously manufactured products and to change the prices or specifications of any product without notice or obligation to any person.
3. REMEDY. In the event the above product fails to meet the above Warranty and the above conditions have been met, the purchaser's sole remedy under this Limited Warranty shall be to return the product to Audio Research or an authorized Audio Research repair center where the defect will be rectified without charge for parts or labor, except vacuum tubes (See 6).
4. LIMITED TO ORIGINAL PURCHASER. This Warranty is for the sole benefit of the original purchaser of the covered product and shall not be transferred to a subsequent purchaser of the product.
5. DURATION OF WARRANTY. This Warranty expires on the third anniversary of the date of purchase or no later than the fifth anniversary of the date of shipment to the authorized Audio Research dealer, whichever comes first.
6. VACUUM TUBES. Vacuum tubes are warranted for the original 90-day period only.
7. DEMONSTRATION EQUIPMENT. Equipment used by an authorized dealer for demonstration purposes is warranted to be free of manufacturing defects in materials and workmanship for a period of three (3) years from the date of shipment to the dealer. Vacuum tubes are warranted for 90 days. Demo equipment needing warranty service must be packed and returned to Audio Research by the dealer at his sole expense. Audio Research will pay return freight of its choice. A returned product must be accompanied by a written description of the defect on an AUDIO RESEARCH RETURNED GOODS AUTHORIZATION form. Dealer-owned demonstration equipment sold at retail within three (3) years of date of shipment to the dealer is warranted to the first retail customer to be free of manufacturing defects in materials and workmanship for the duration of the 3-Year Limited Warranty remaining (as measured from the date of shipment of the equipment to the dealer). Vacuum tubes are not warranted for any period under these conditions of sale. In the event warranty service is needed under these conditions, the owner of

the equipment must provide a copy of his purchase receipt, fulfilling the requirements described under "2. Conditions" above. The product must be packed and returned to Audio Research or an authorized Audio Research repair center by the customer at his or her sole expense. Audio Research will pay return freight of its choice.

8. MISCELLANEOUS. ANY IMPLIED WARRANTIES RELATING TO THE ABOVE PRODUCT SHALL BE LIMITED TO THE DURATION OF THIS WARRANTY. THE WARRANTY DOES NOT EXTEND TO ANY INCIDENTAL OR CONSEQUENTIAL COSTS OR DAMAGES TO THE PURCHASER. Some states do not allow limitations on how long an implied warranty lasts or an exclusion or limitation of incidental or consequential damages, so the above limitations or exclusions may not apply to you. This Warranty gives you specific legal rights, and you may also have other rights which vary from state to state.

9. WARRANTOR. Inquiries regarding the above Limited Warranty may be sent to the following address:

Audio Research Corporation
6801 Shingle Creek Parkway
Minneapolis, MN 55430

WARRANTY OUTSIDE THE USA

Audio Research has formal distribution in many of the countries of the free world. In each country the Audio Research Importer has contractually accepted the responsibility for product warranty. Warranty should normally be obtained from the importing dealer or distributor from whom you obtain your product.

In the unlikely event of service need beyond the capability of the Importer, Audio Research does, of course, back up the warranty. Such product would need to be returned to Audio Research, together with a photostatic copy of the bill of sale.

SP-7 SPECIFICATIONS

Frequency Response:

High level section: $\pm .25$ dB, 1Hz to 50kHz
-3dB points below 0.1Hz and above 400kHz
Magnetic phono: $\pm .25$ dB of RIAA, 10Hz to 40kHz

Harmonic Distortion:

Less than .002% at 2V RMS output, 20Hz to 20kHz
(typically less than .0005% in midband)

Intermodulation Distortion:

Less than .002% at 2V RMS output

Gain:

Magnetic phono input to tape output: 28dB
Magnetic phono input to main output: 60dB
High level inputs to main output: 26dB

Input Impedance:

50K ohms phono, 90K ohms high level inputs. Also has provision to add to the 30pF phono input capacitance for matching certain magnetic cartridges.

Output Impedance:

250 ohms main output; 1200 ohms tape output. Recommended minimum load for best audio quality 600 ohms and .01 μ F maximum capacitance main output, 10K ohms and 200pF maximum capacitance tape output.

Maximum Inputs:

Magnetic phono, 500mV at 1kHz. (2.0V RMS, 10kHz) High level inputs essentially overload-proof.

Rated Outputs:

2V RMS 1Hz to 50kHz, all outputs; 10K ohm load (maximum main output capability is 14V RMS output at 1/2% THD at 1Hz to 50kHz into a 10K ohm load, 10V RMS at 1/2% THD at 1Hz to 50kHz into a 600 ohm load)

Power Supplies:

Four electronically-regulated tracking solid-state supplies. Line regulation better than .01%.

Noise:

High Level

- (1) 250 μ V RMS maximum residual unweighted 100kHz bandwidth noise at main output with gain control minimum (86dB below 5V RMS output)
- (2) More than 90dB below 1V RMS input (less than 20 μ V equivalent input noise)

Magnetic Phono

2 μ V equivalent input noise, wideband RMS (-74dB reference 10mV input)
Less than 1 μ V above 200Hz or -80dB reference 10mV input)

Amplification:

Four AM8 Analog Modules.[®] (No coupling capacitors.)

Power Requirements:

100-130VAC 60Hz (190-250VAC 50Hz) >10 Watts

Dimensions:

19" (48 cm) W x 3 1/2" (8.9 cm) H (standard rack panel) x 8 1/2" (21 cm) D.
Handles extend 1 1/2" (3.8 cm) forward of front panel. Rear chassis fittings extend 3/4" (1.9 cm).

Weight:

16 lbs. (7.3 kg) Net; 20 lbs. (9.1 kg) Shipping

SP-7 PREAMPLIFIER

SCHEMATIC

5-17-84

audio research corporation

6801 SHINGLE CREEK PARKWAY
MINNEAPOLIS, MINNESOTA 55430

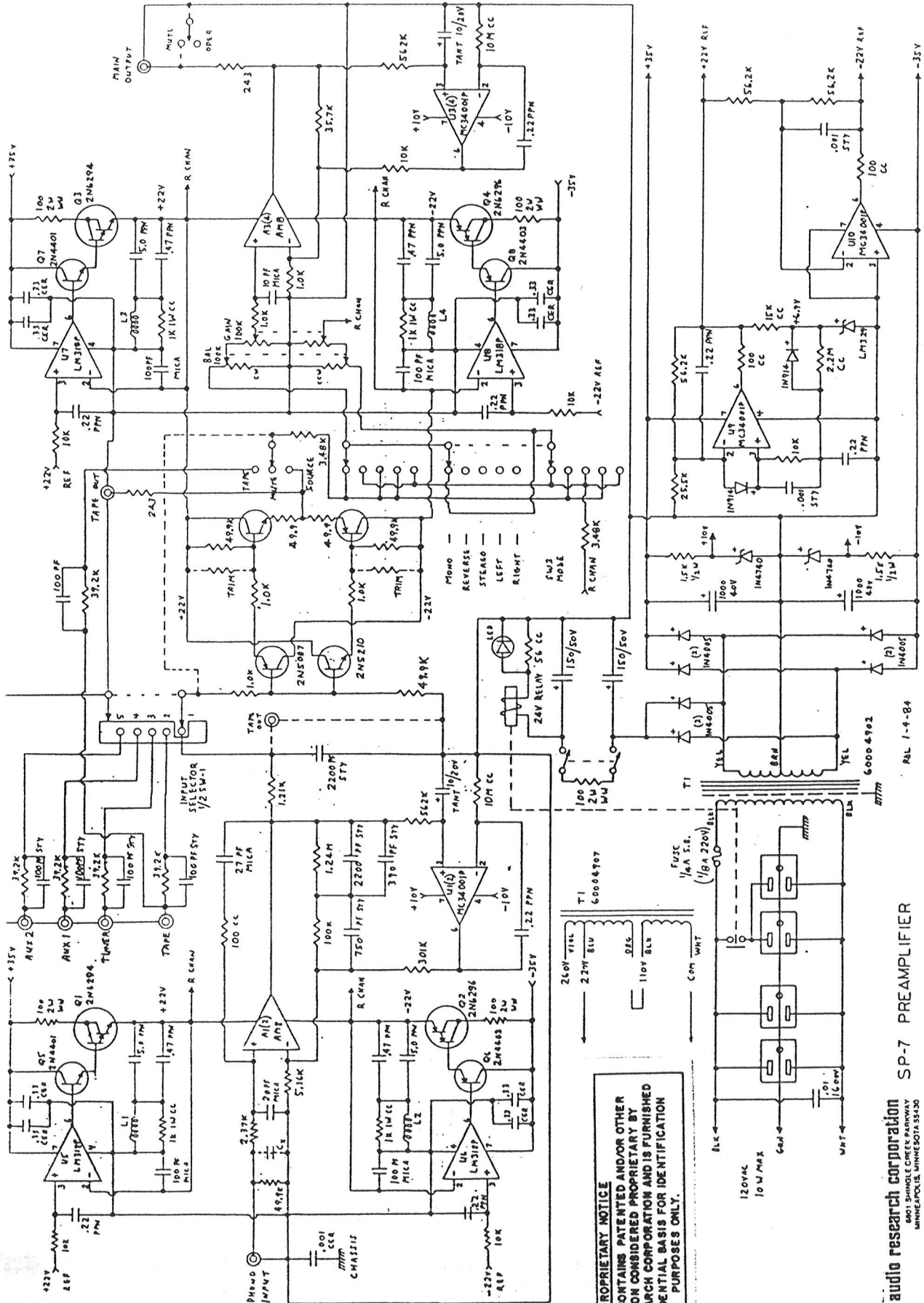

PROPRIETARY NOTICE
 THIS PRINT CONTAINS PATENTED AND/OR OTHER
 INFORMATION CONSIDERED PROPRIETARY BY
 AUDIO RESEARCH CORPORATION AND IS FURNISHED
 ON A CONFIDENTIAL BASIS FOR IDENTIFICATION
 PURPOSES ONLY.

audio research corporation
 801 SHUNGLER CREEK PARKWAY
 MINNEAPOLIS, MINNESOTA 55430

SP-7 PREAMPLIFIER
 PAL 1-4-84